

Chain Wheels

Quickkits supply a range of ductile iron or stainless steel chain operators that are designed and manufactured to our high quality standard.



SPECIFICATION

- Ductile iron construction
- Powder coated finish as standard
- Galvanised chain
- Quick-link chain connection
- Universal mounting (handwheel clamps / direct mount)
- Safety cable kit included as standard



OPTIONS

- 316 stainless chainwheel and chain available upon request
- Powder coating finishes in any RAL colour
- Special offshore paint specifications and finishes available
- Exotic materials are available on request



**SAME DAY
DESPATCH
AVAILABLE**

Dimensions & Technical Details

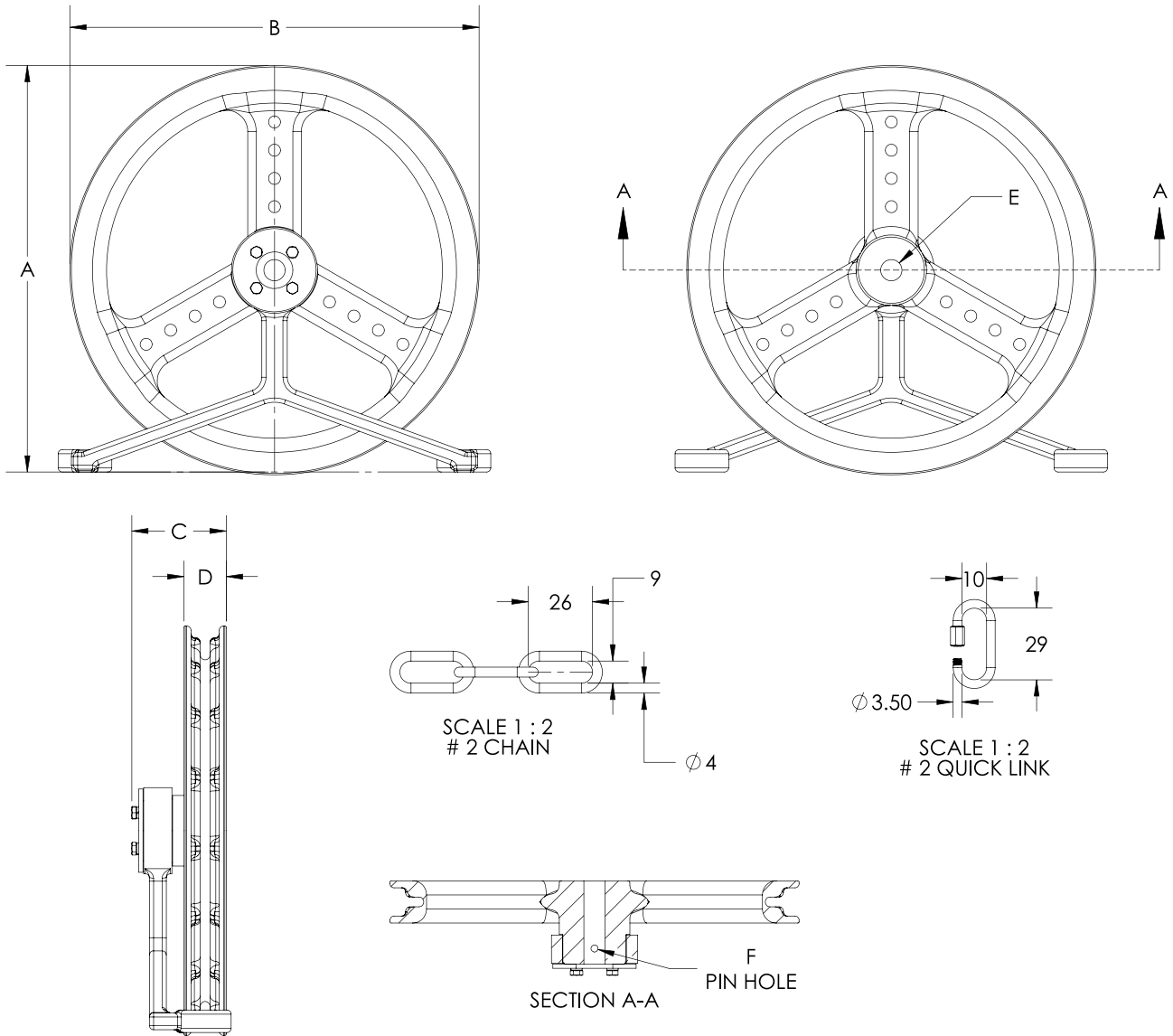

Type	A	B	C	D	E	F	Applicable Handwheel Sizes	C/W Weight (Excl. Chain)	Chain Type	Chain Weight (Per Mtr)	Quick Link Type
QKCW #01	201	200	67	30	12	4	Ø150 & Ø200	3.8 Kg	# 2 CHAIN	0.25 Kg	# 2 LINK
QKCW #02	288	290	67	30	15	5	Ø250 & Ø300	5.6 Kg			
QKCW #03	399	410	72	33	20	6	Ø350 & Ø400	10.3 Kg			
QKCW #04	549	574	73	35	25	8	Ø400, Ø450 & Ø500	13.6 Kg			